

RAČUNARSKA ELEKTRONIKA
(3P+1V+1L) (6. SEMESTAR)
ODSEK ZA ELEKTRONIKU

PROFESOR:
Dr Milan Prokin

LITERATURA:

**Milan Prokin, “Računarska
elektronika”, Akademska misao,
Beograd, 2006**

MIKROPROCESOR III GENERACIJE

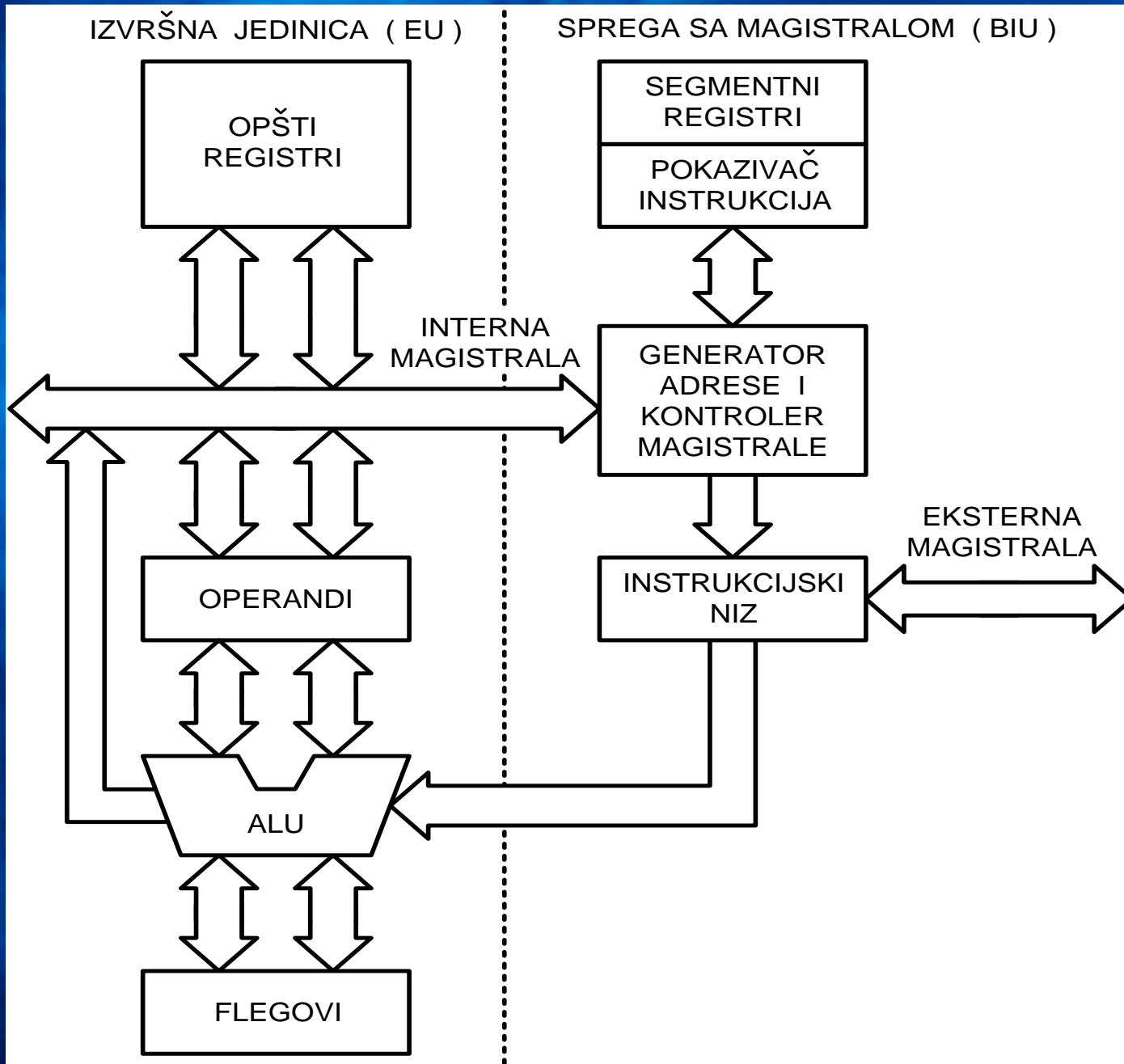

MAGISTRALNI CIKLUS UPISA

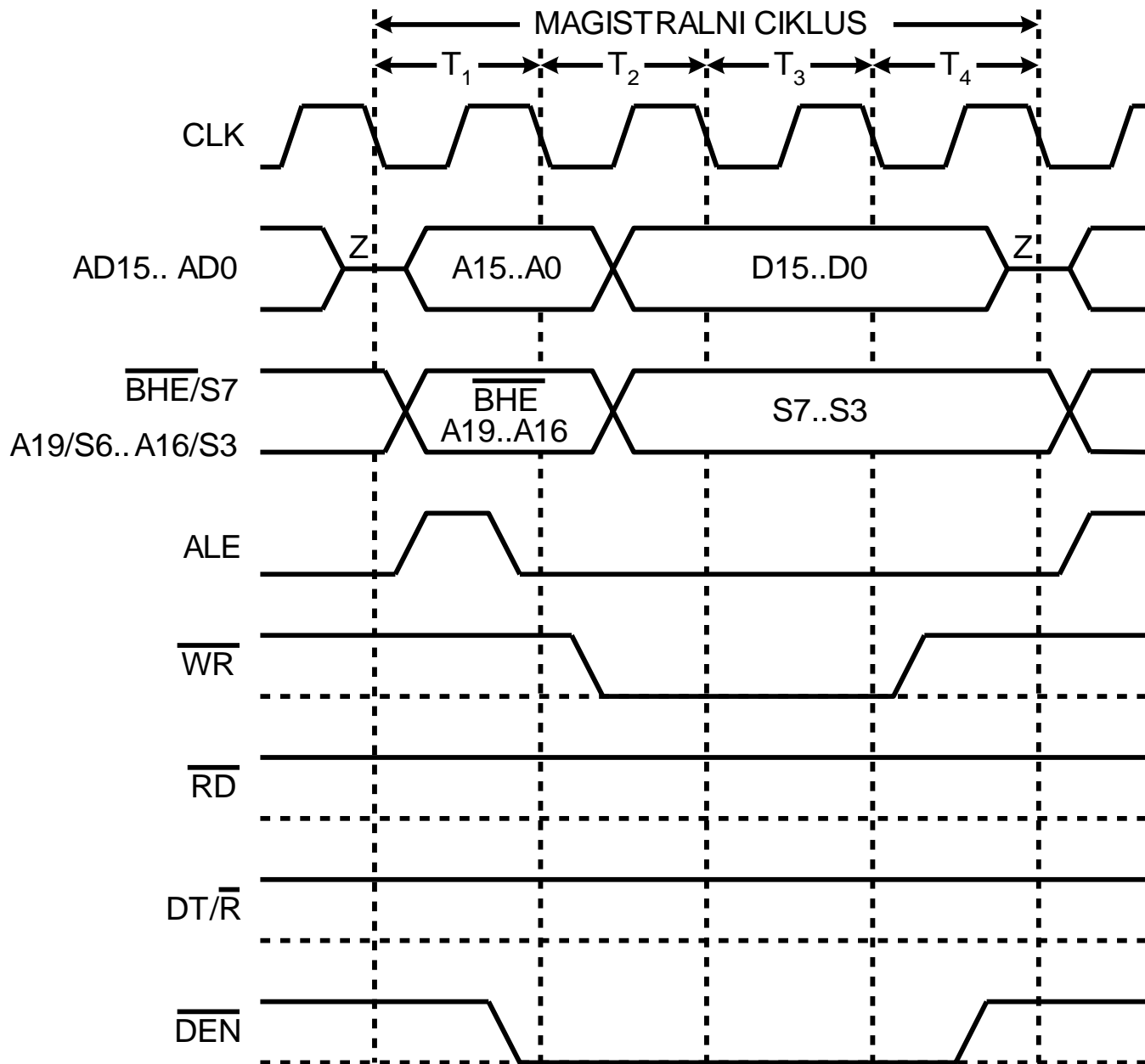

SPREGA SA MAGISTRALAMA

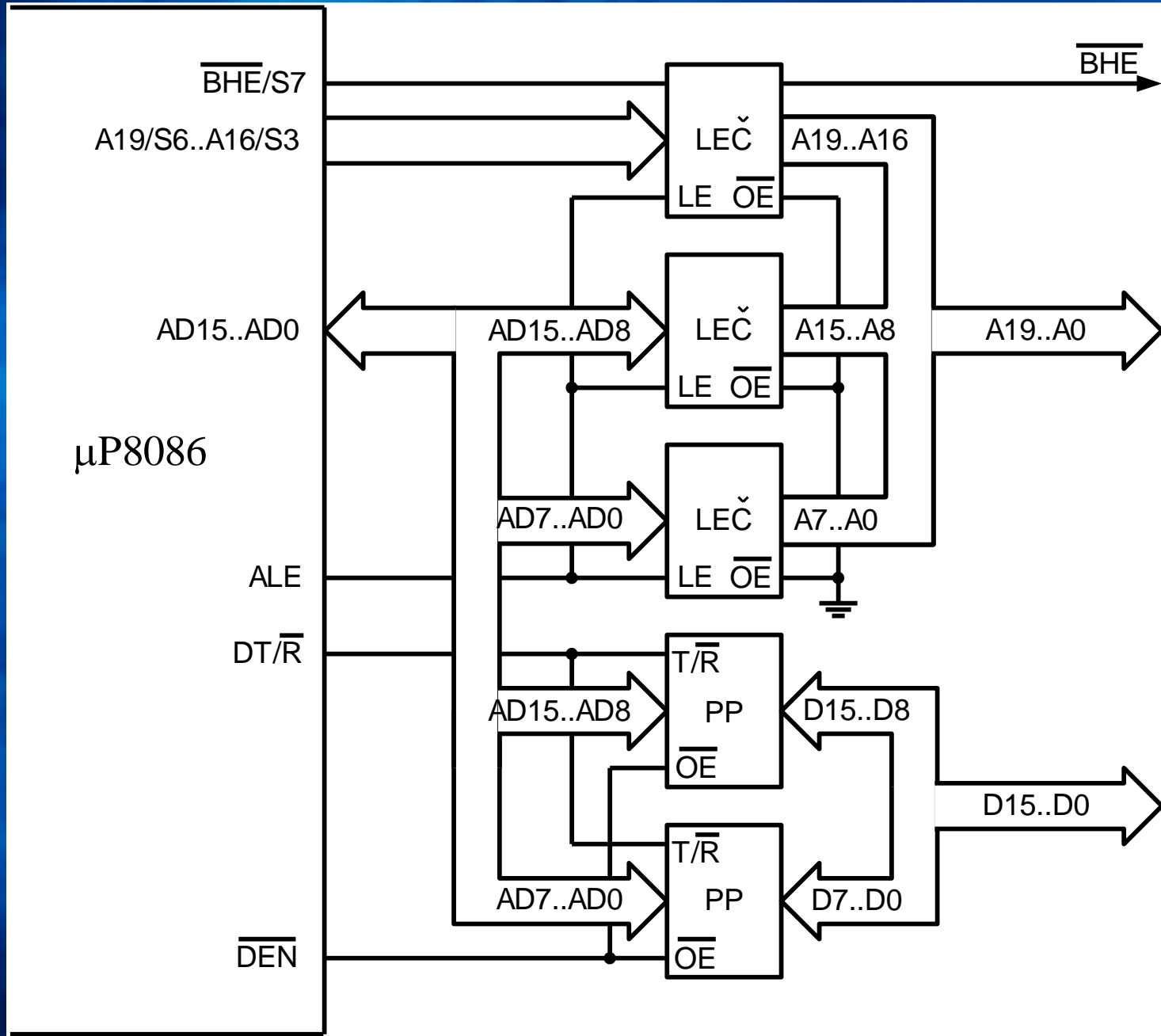

ADRESIRANJE DVA EPROMA 32Kx8

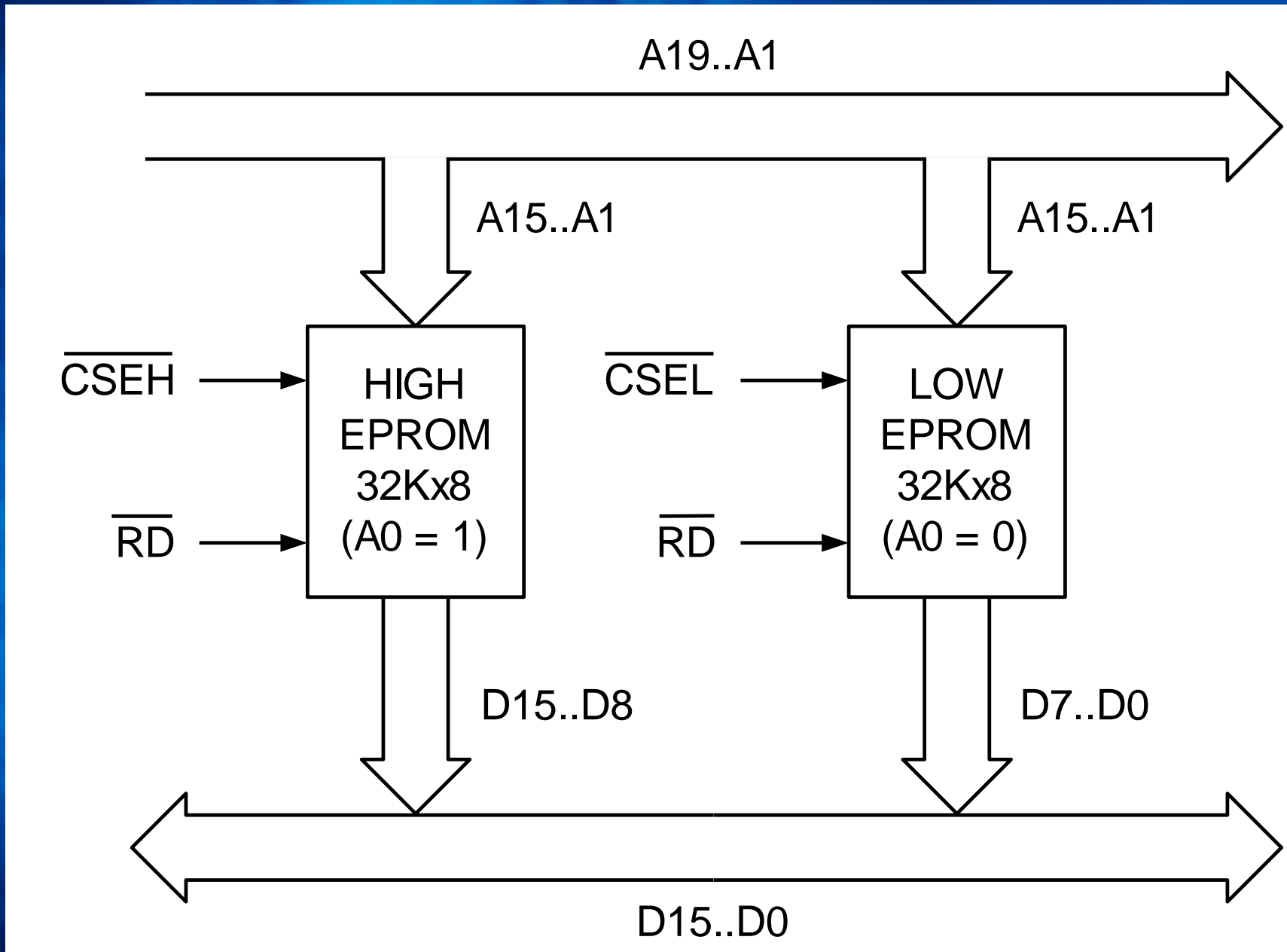

ADRESIRANJE DVA RAMA 8Kx8

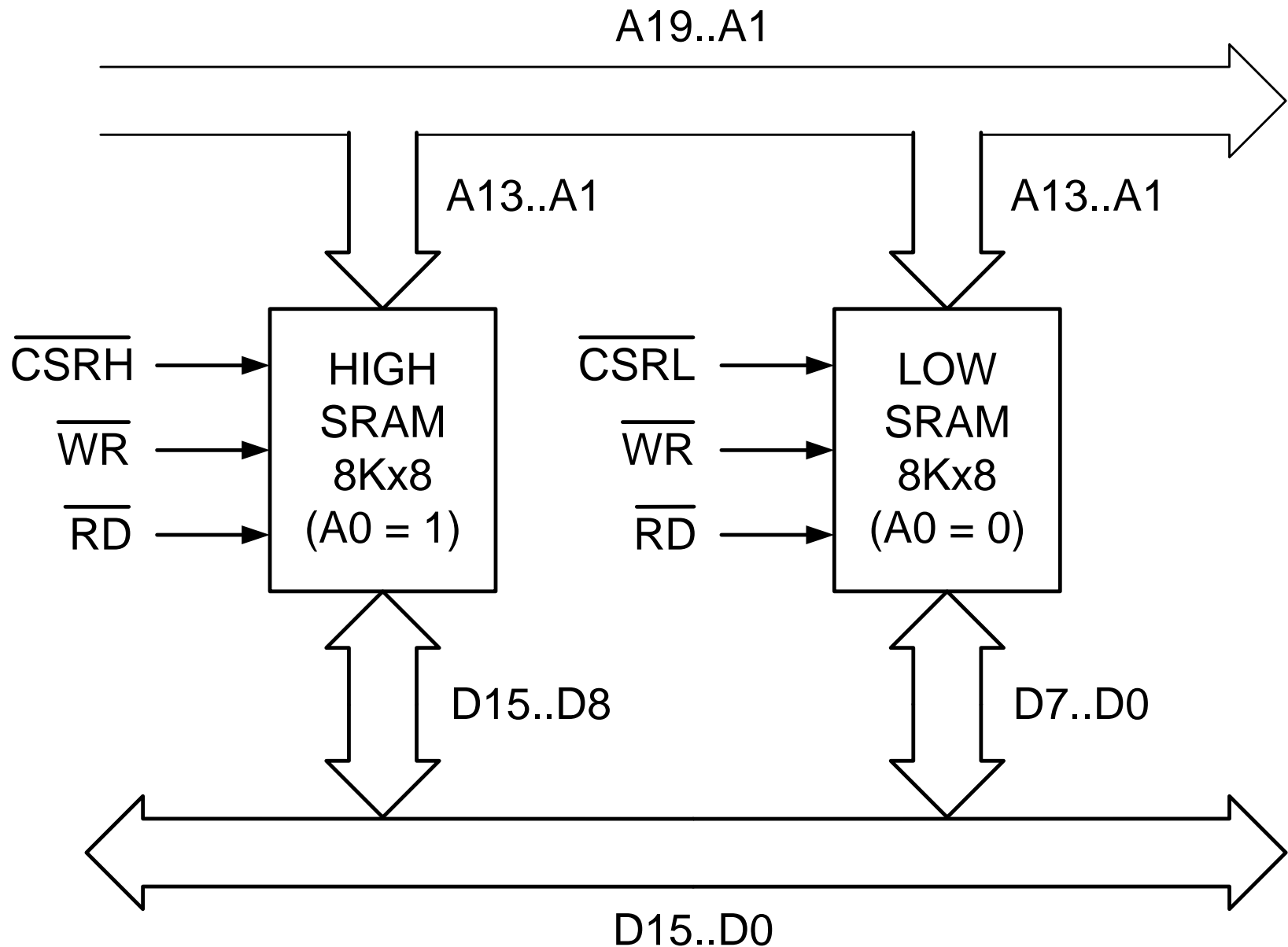

PROGRAMIRANJE U ASEMBLERU

```
push    bp
mov     bp,sp
push    si
push    ds
mov     ax,GRABBER_DATA
mov     ds,ax
les     bx,dword ptr [bp+6]
mov     ax,word ptr es:[bx]
shr     ax,8
and     ax,3
inc     ax
and     ax,3
and     ax,3
and     word ptr es:[bx],-769
shl     ax,8
or      word ptr es:[bx],ax
```

KONTROLER PREKIDA 8259A

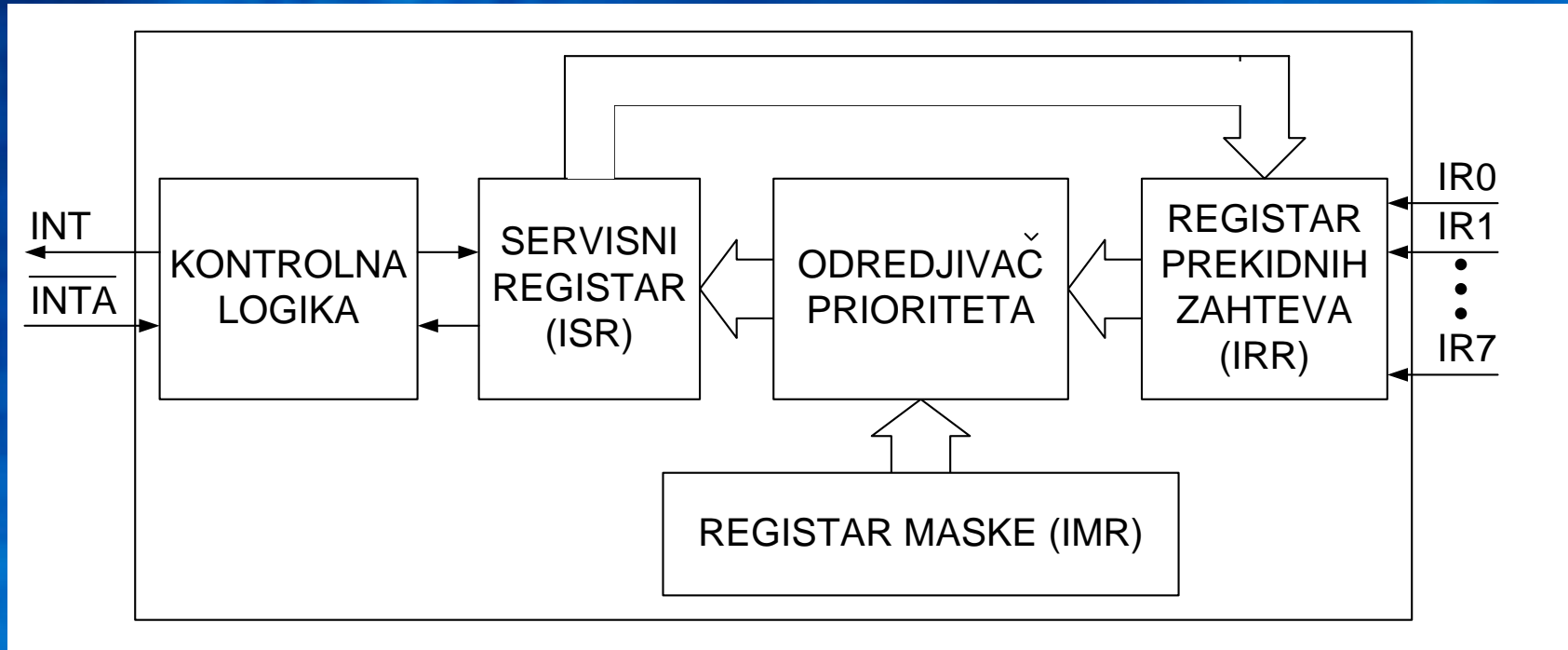

- **Magistralni ciklusi kontrolera prekida**

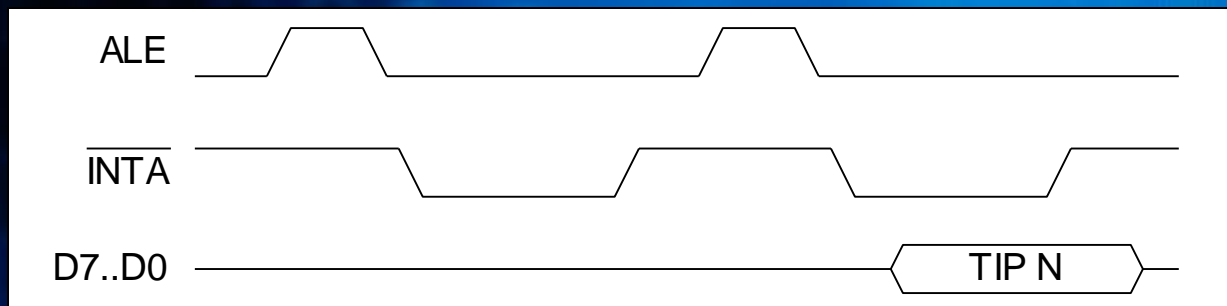

PROGRAMABILNI TAJMER SA BROJAČEM NADOLE

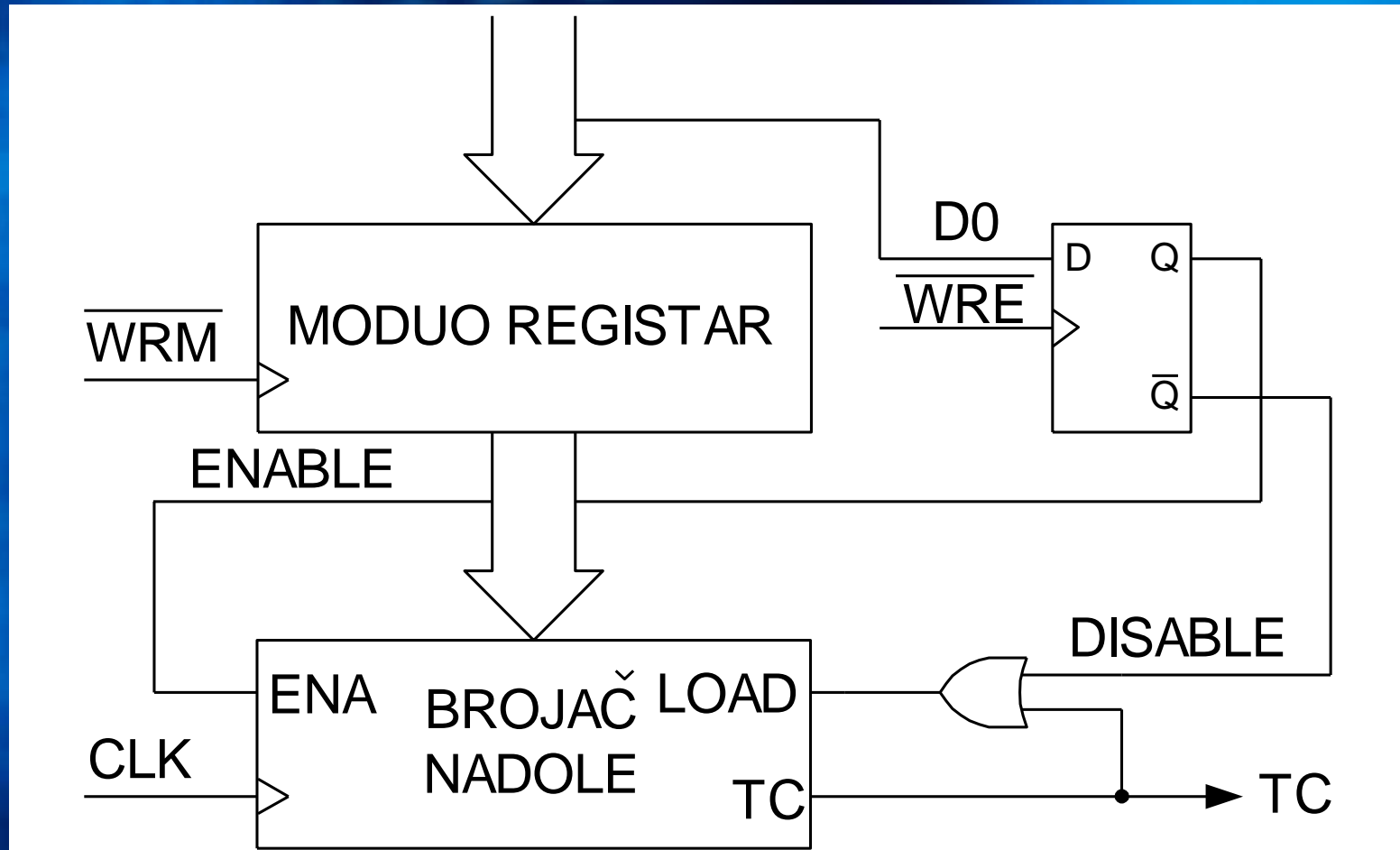

VREMENSKI DIJAGRAMI

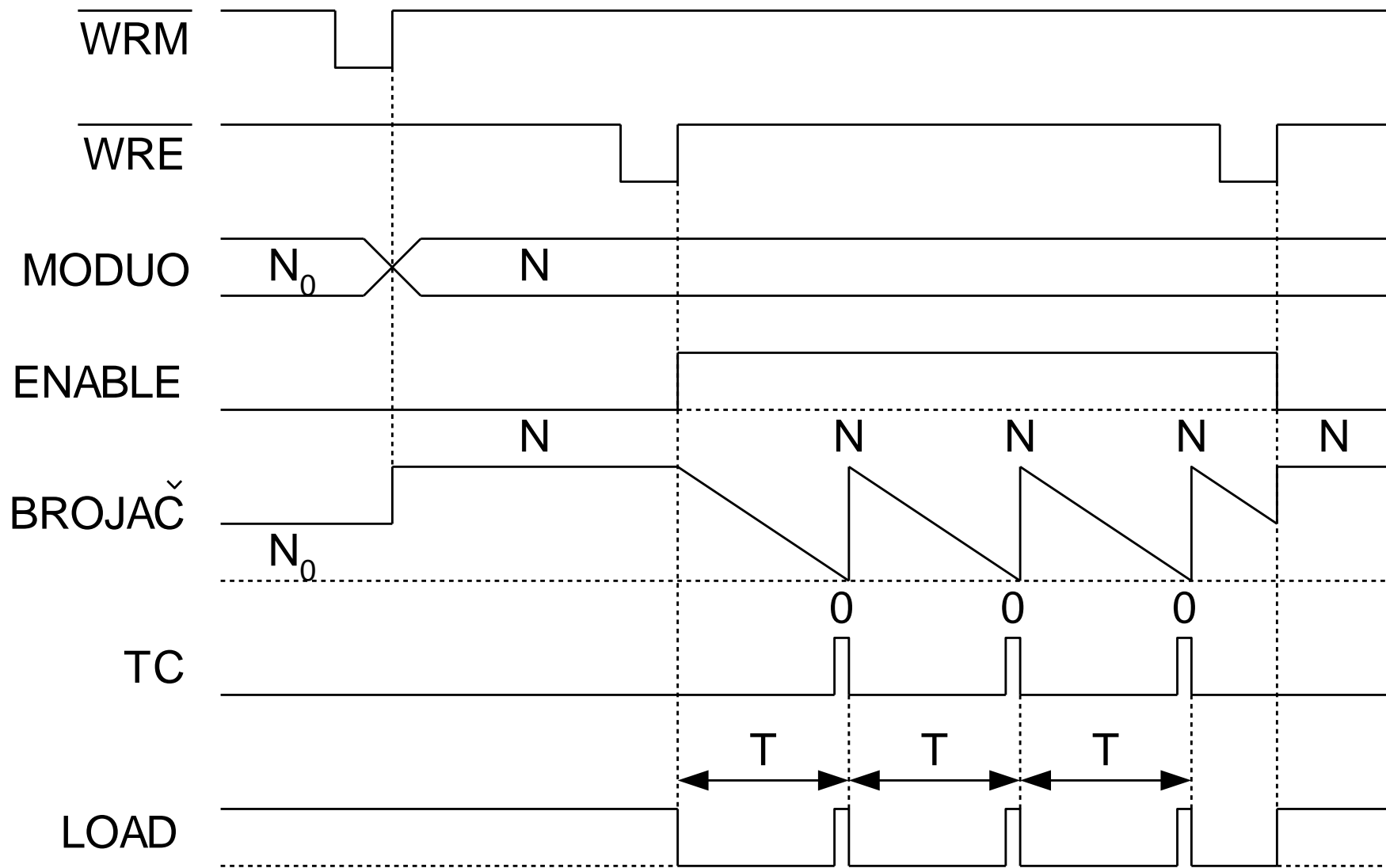

ČITANJE BROJAČA NA UZLAZNOJ IVICI TAKTA

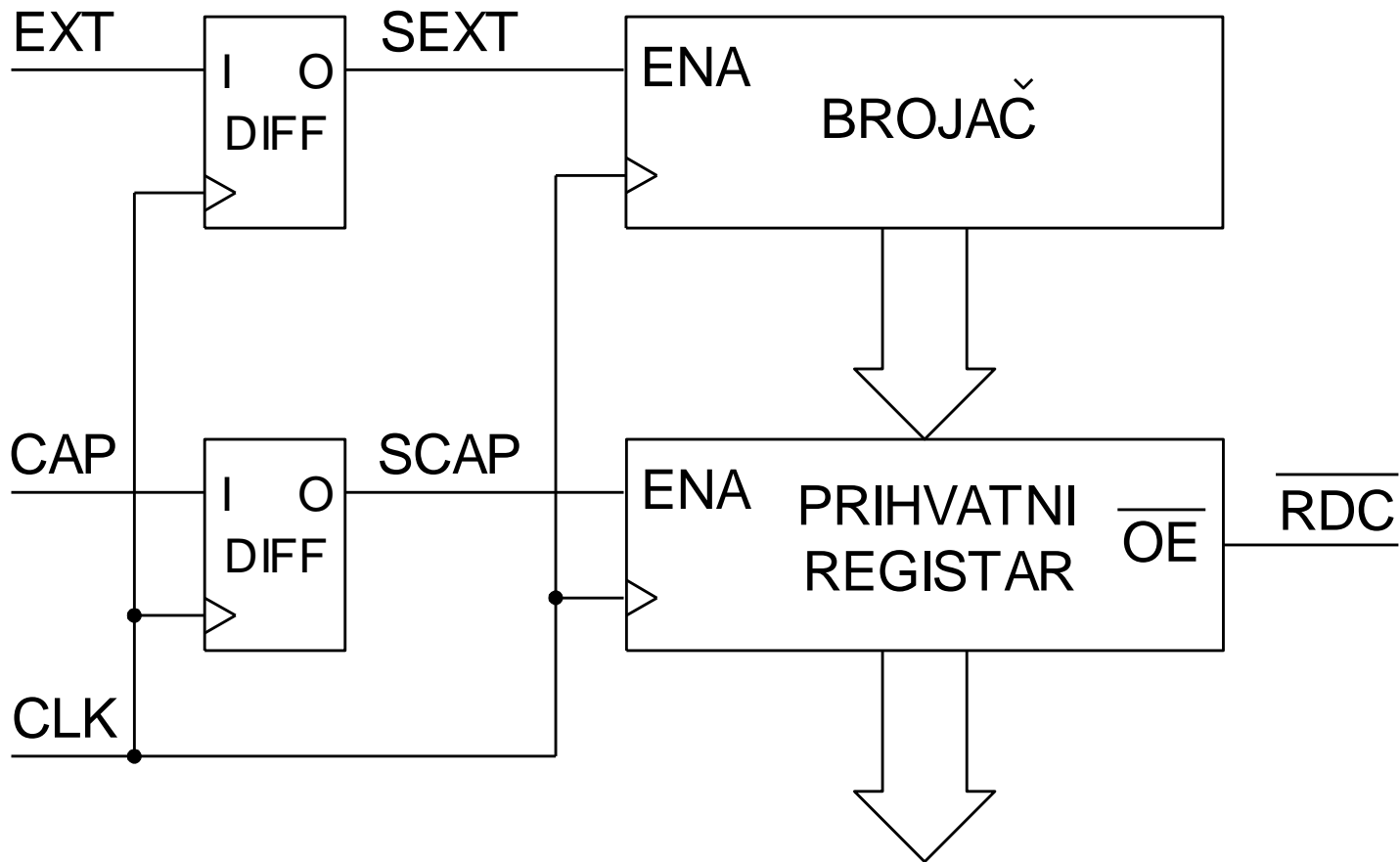

INTEGRISANI GENERATOR RESETA I NMI

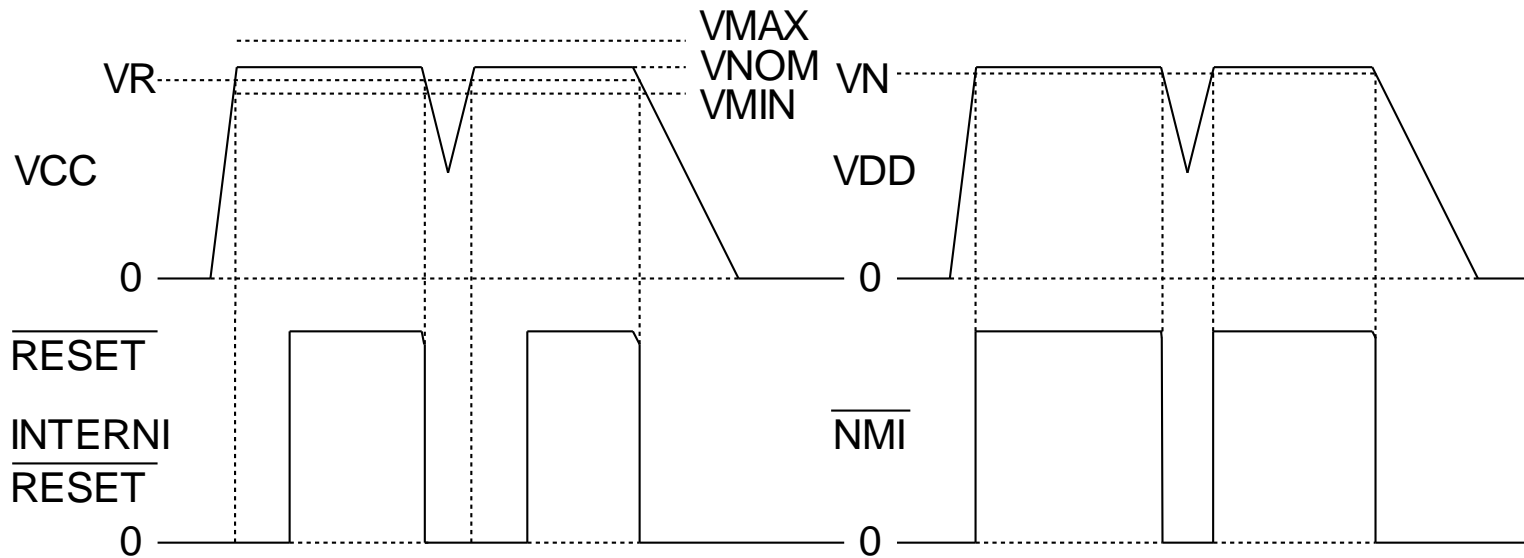
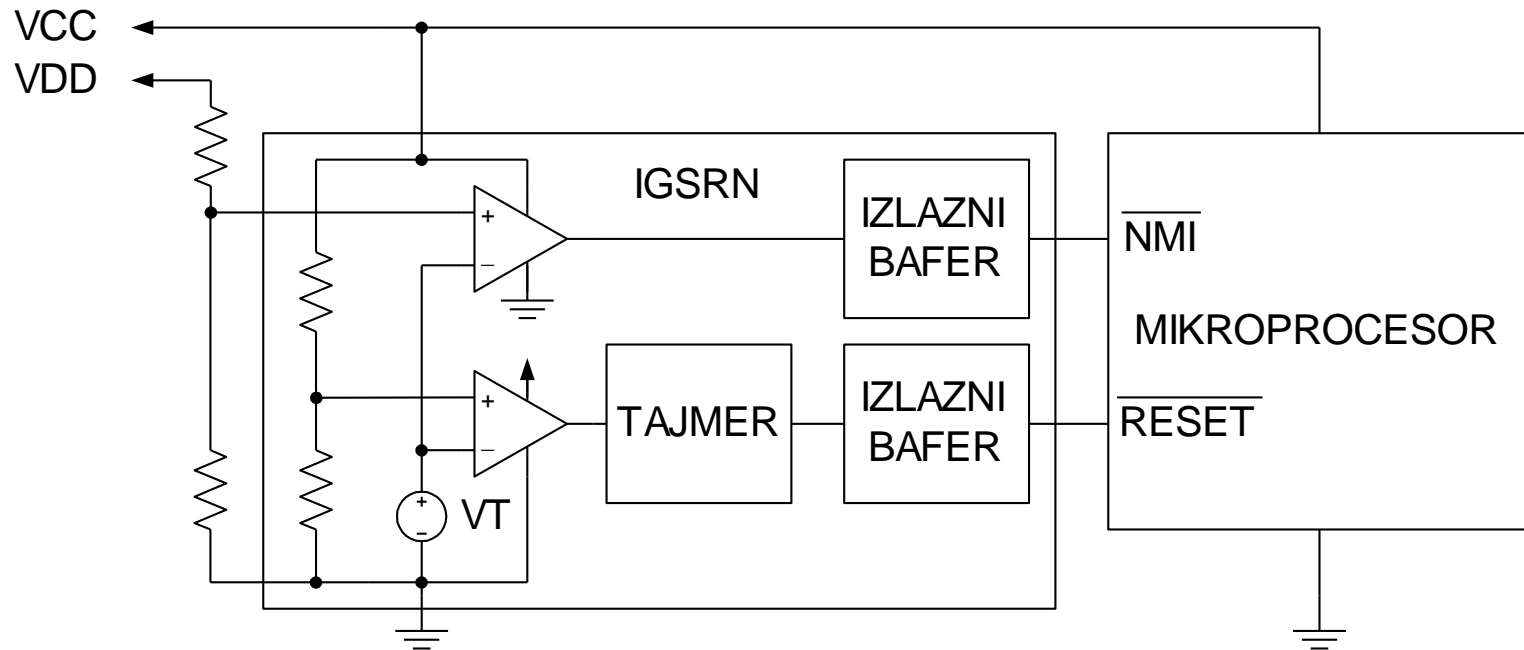

DIREKTAN PRISTUP MEMORIJI (DMA)

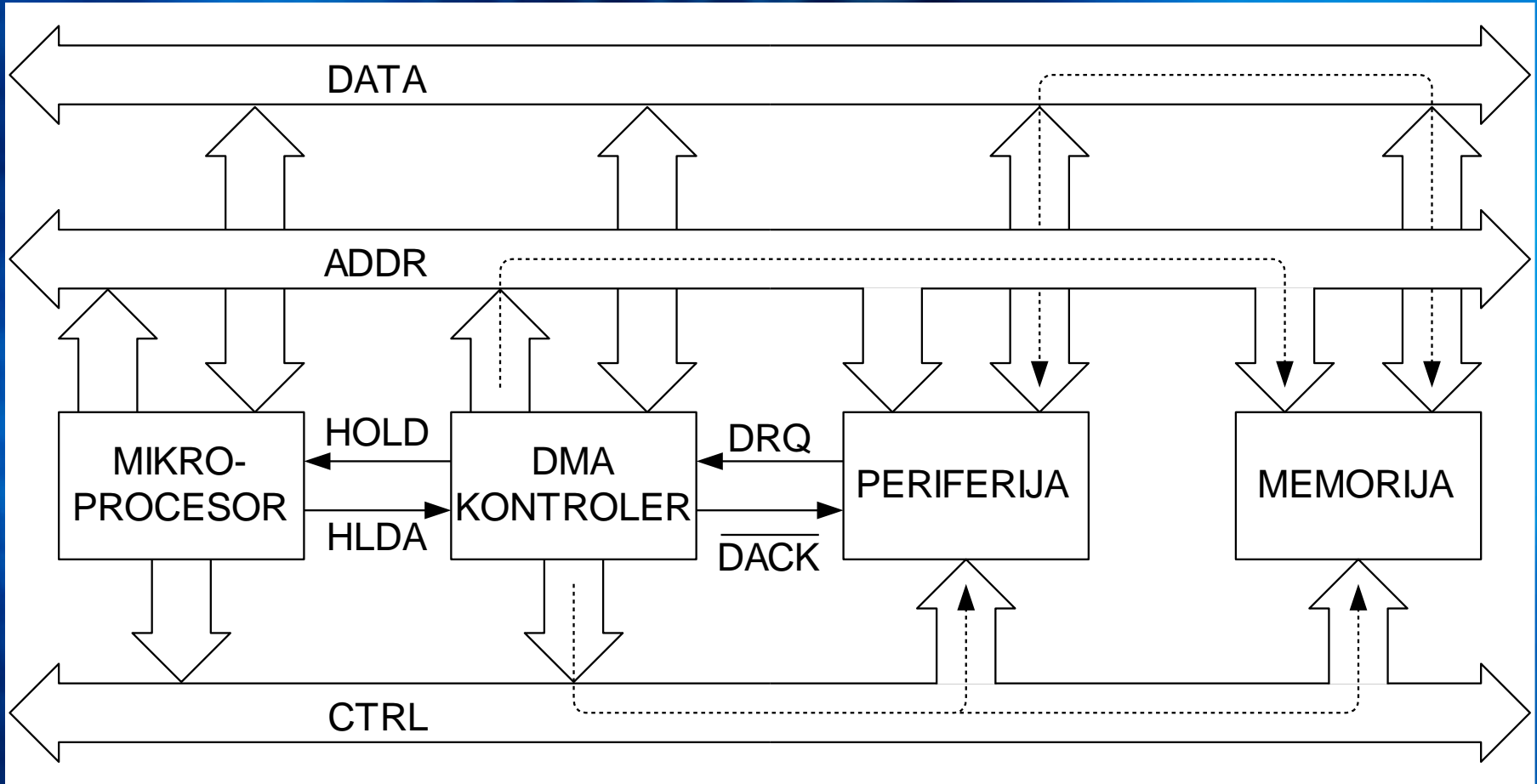

SPREGA SA MULTIPLEKSIRANOM TASTATUROM

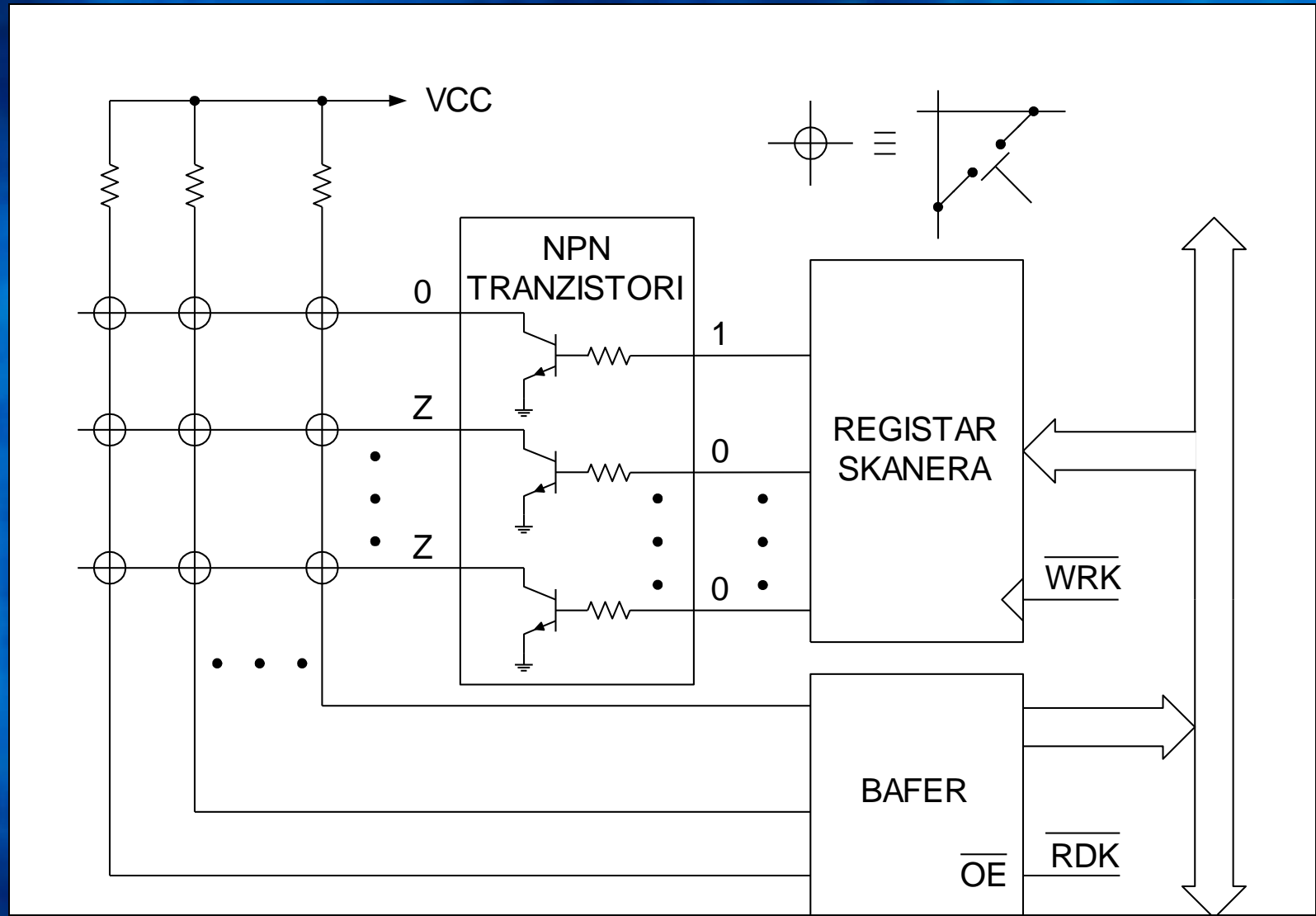

SOFTVERSKO DEBAUNSIKIRANJE

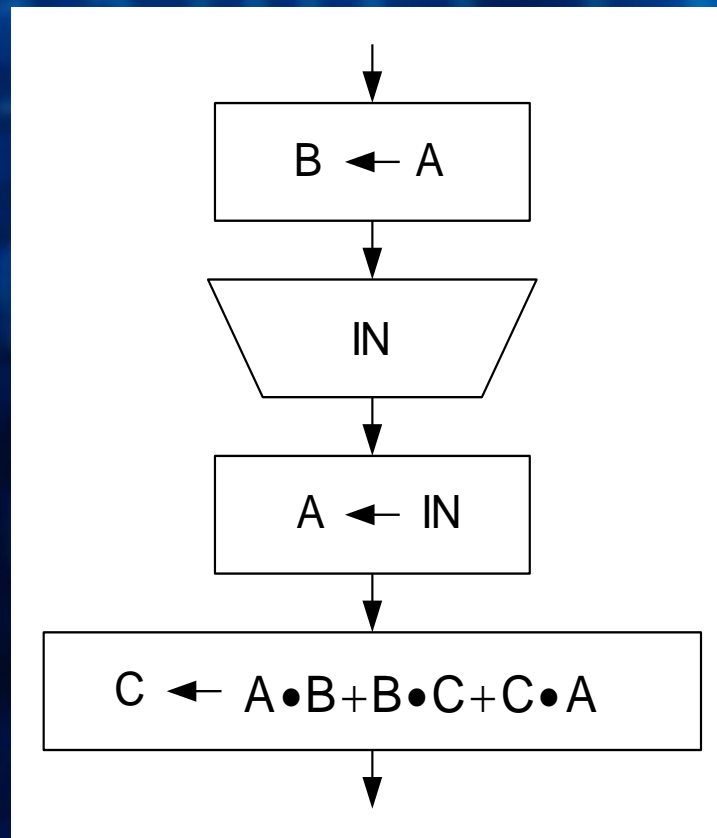

ZAŠTITA ULAZNIH LINIJA

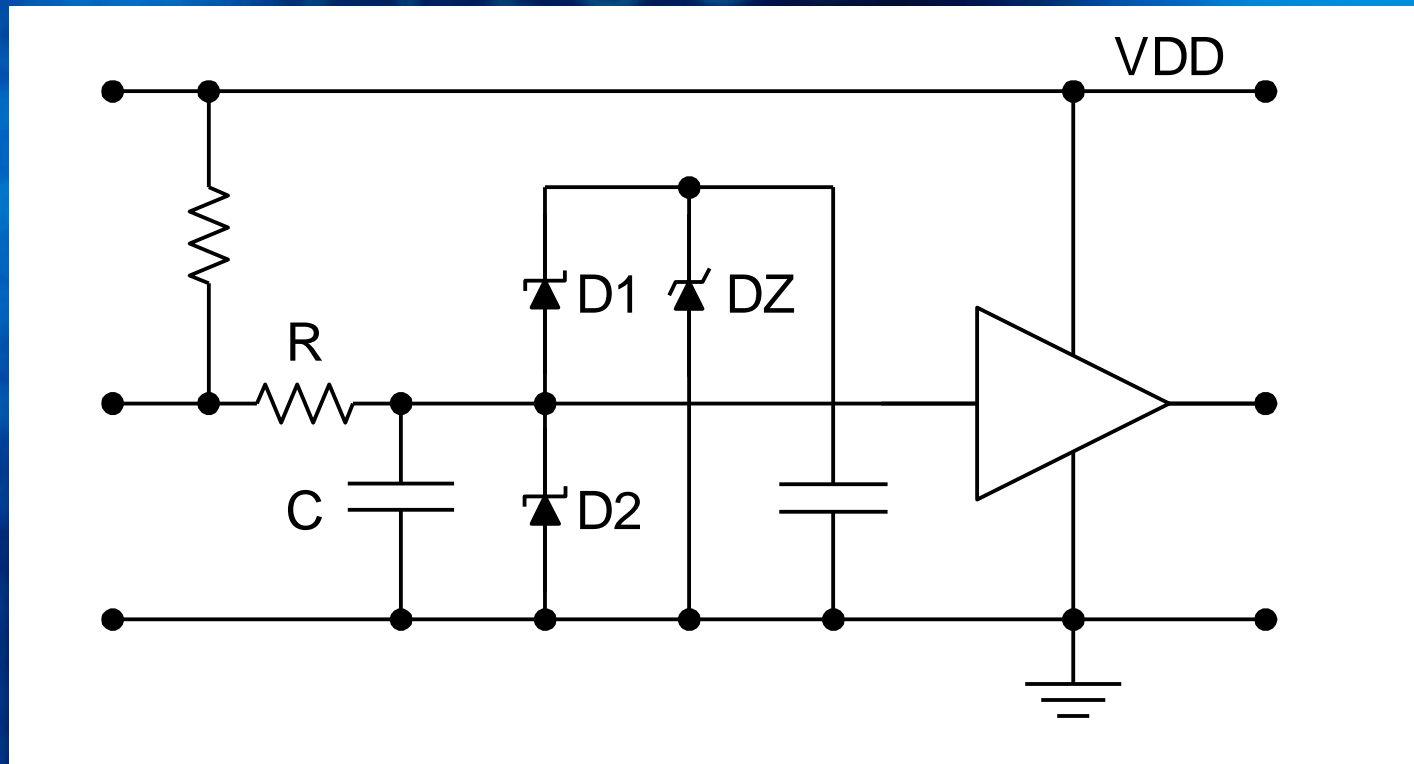

MULTIPEKSIRANI SEGMENTNI LED SA ZAJEDNIČKOM KATODOM

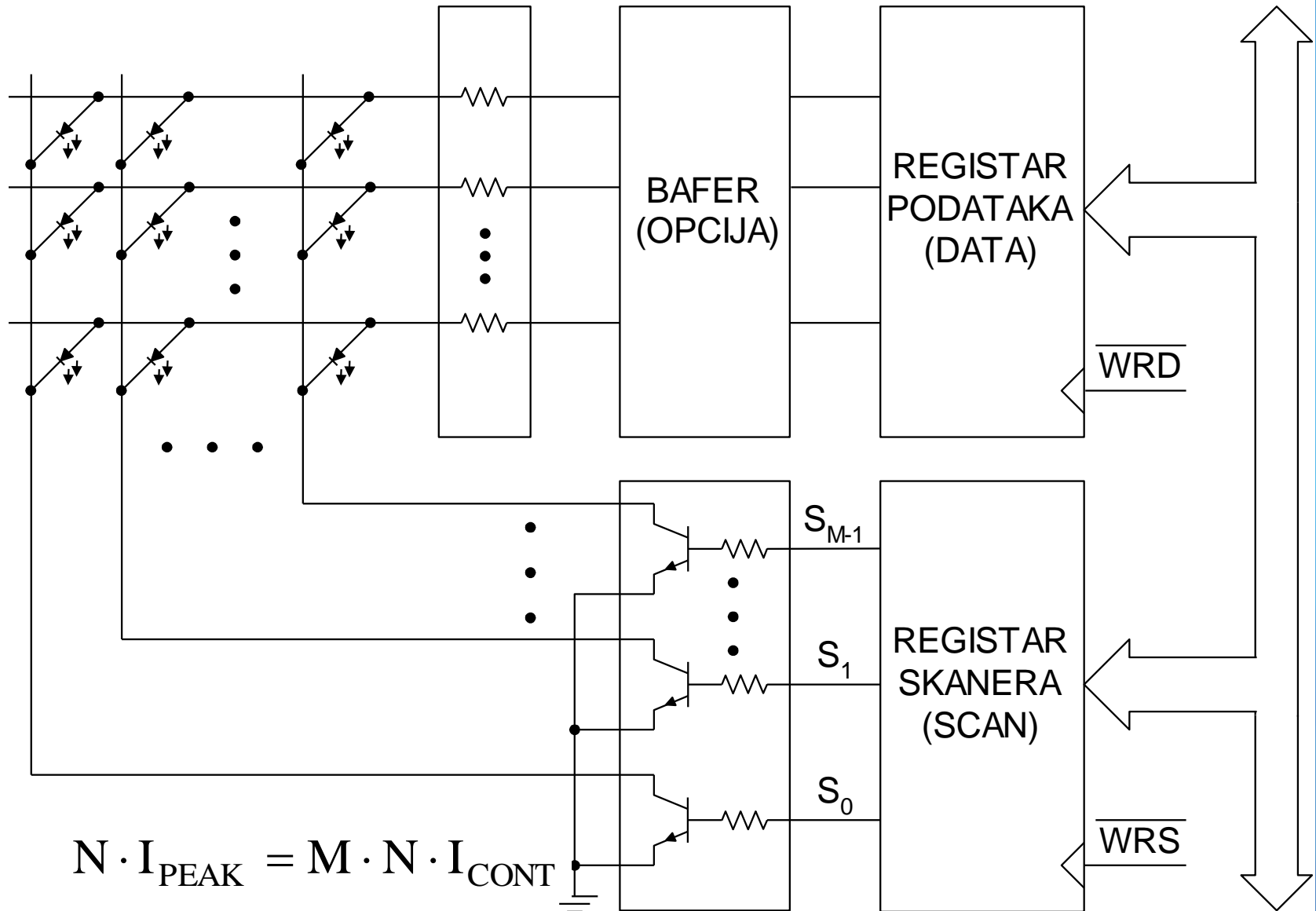

ALFANUMERIČKI LCD MODUL

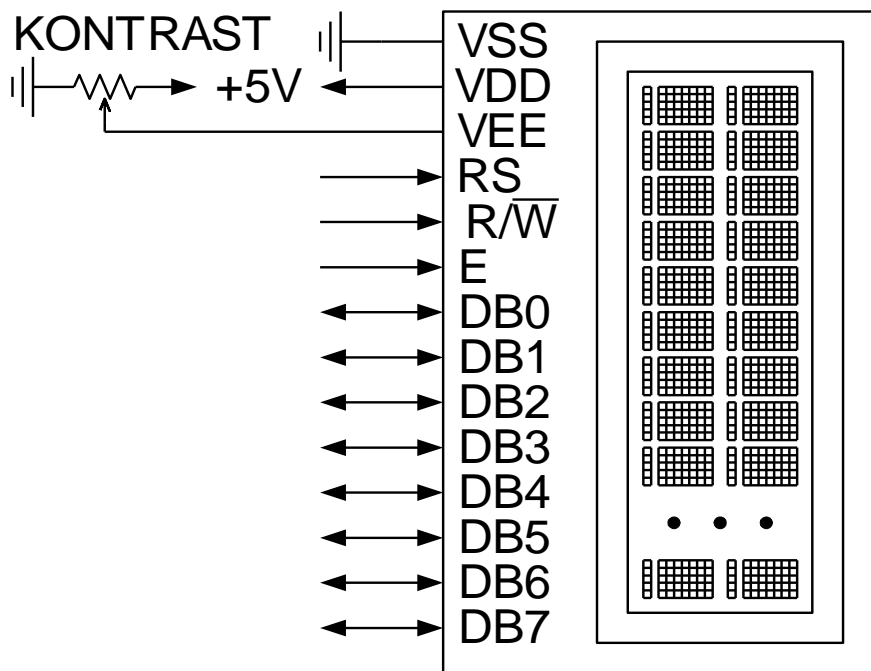

a) LCD

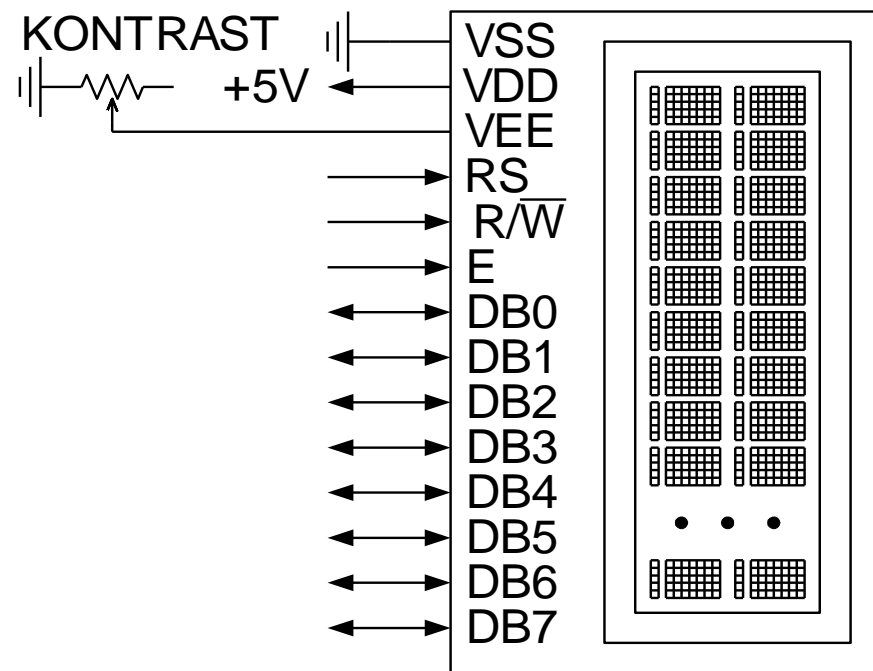

b) LCD

FIFO MEMORIJA

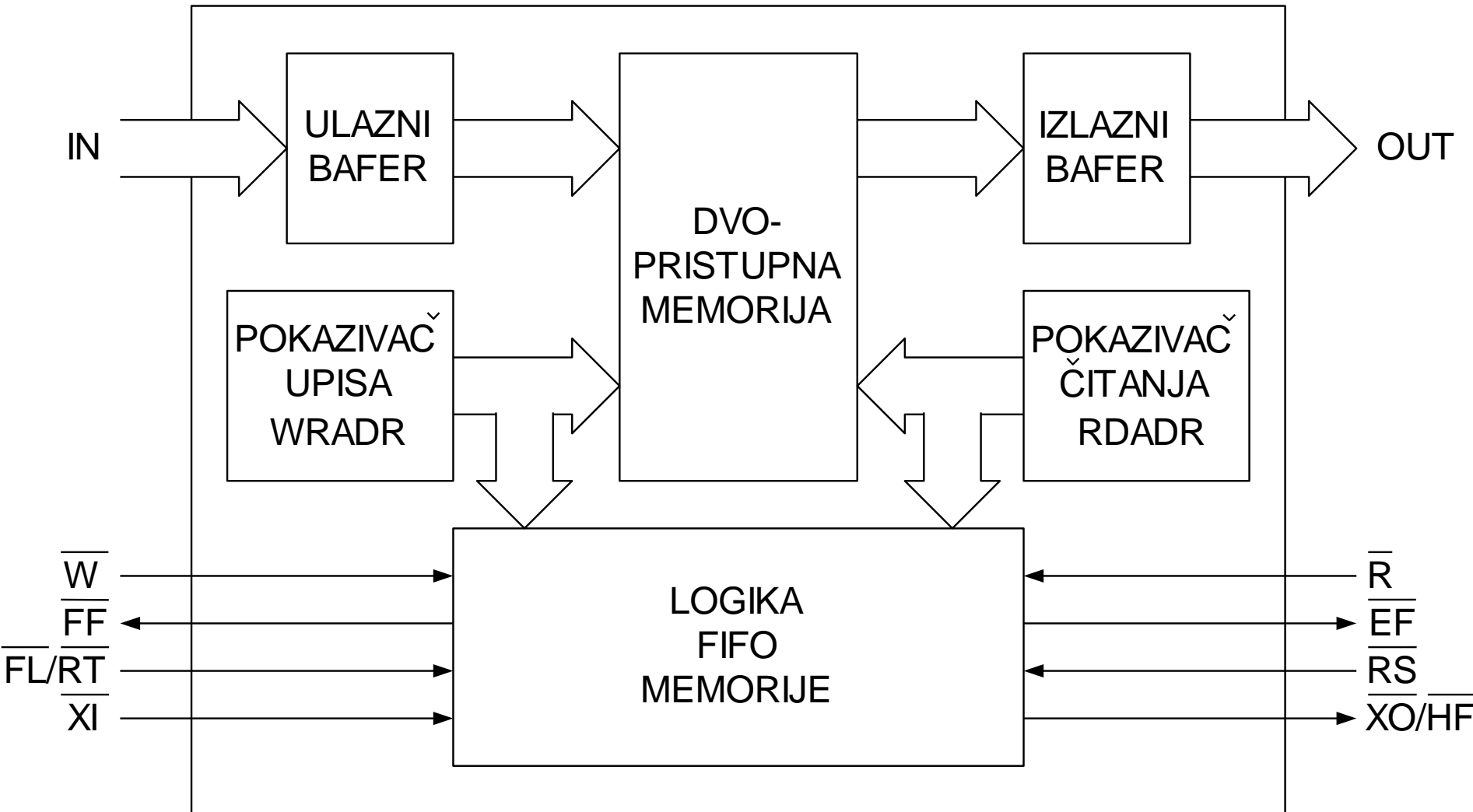

POLAGANJE ISPITA

30% OCENE = PROJEKAT

70% OCENE = PISMENI ISPIT

Arhitektura i organizacija računara

RAČUNARSKA ELEKTRONIKA

Namenski računarski sistemi

Digitalni procesori signala

Elektronski merni sistemi

Sistemi u realnom vremenu



Hand-held (HPC)



PDA



Laptop



Desktop



Tower



Workstation